



VRT18X1

DATASHEET



Cooling & heating - capacity

Cooling capacity KW	min 3,8	std 14	max 18
Cooling power source KW	min 0,8	std 2,3	max 4,0
Heating capacity KW	min 3,8	std 14	max 18
Heating power source KW	min 0,8	std 2,3	max 4,0

Total BTU Capacity:

Power supply options:

Comparable to 80.000 BTU/h of the competitors.
 180 – 250 VAC 1Phase 50/60Hz → *mod. VRT18X1-2V*
 On request: 400VAC → *mod. VRT18X1-4V*
 On request: 700VDC → *mod. VRT18X1-7V*

Sea water pump:

Magnetic type 100W included in unit power consumption.
 100 lt/min

Size W x D x H:

558 x 467 x 443 mm

Weight:

48 Kg

Sea water working range:

+3°C to +40°C Option polar water: -5°C

Air working range:

-20°C to +50°C

Noise:

Compressor @ 140 hz – 45 db @ 1 meter from box

Vibration:

No significant vibration transmitted to the feet

Sea water pipe connection:

1"

Refrigerant pipe:

5/8" Gas 1/2" Liquid

Compressor box use VRT inverter architecture with refrigerant circulation inside air handler
 Databus rs485 modbus on board.

System based on Toshiba VFD and twin rotary compressor.



CONDENSER:

Titanium Grade 2. No fouling, no corrosion. 3 times lighter than copper nickel
Titanium is an everlasting material that assure to your system long reliability



COMPRESSOR:

Toshiba inverter twin rotary. COP > 4



FRAME:

Stainless Steel 316



SOFTWARE MANAGEMENT:

Compressor high temperature, low temperature, high pressure condenser, low pressure compressor, electronic pressure gas, electronic pressure liquid, Condensation control, Evaporation control



COMPRESSOR PROTECTION:

Over/undervoltage, overcurrent, torque, winding temperature, stepout (bad lubrication), power input, power output, efficiency, overload, oil level (with EEV)

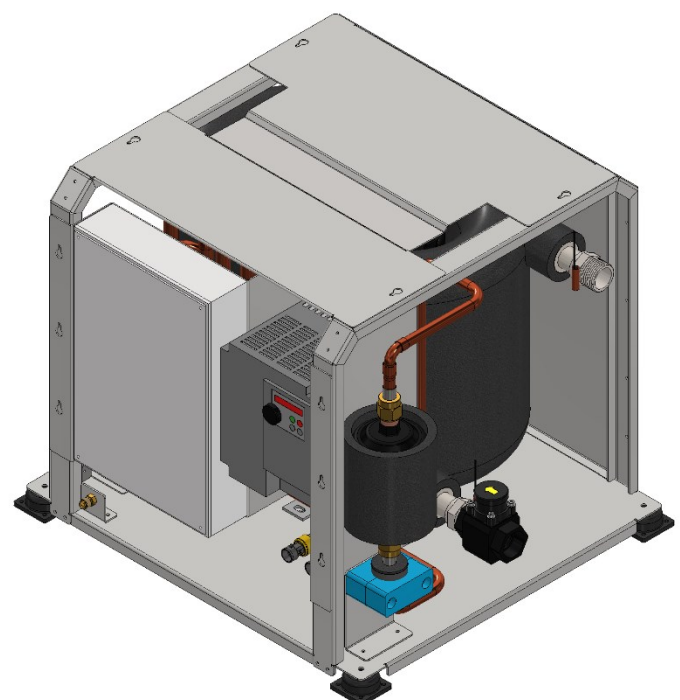
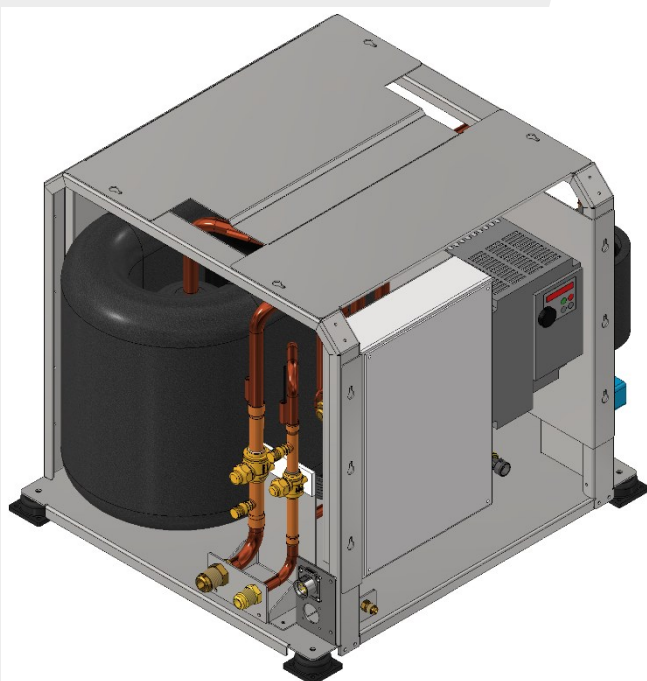

VRT18X1

PERFORMANCE CURVE
DC INVERTER 70 rps / 100

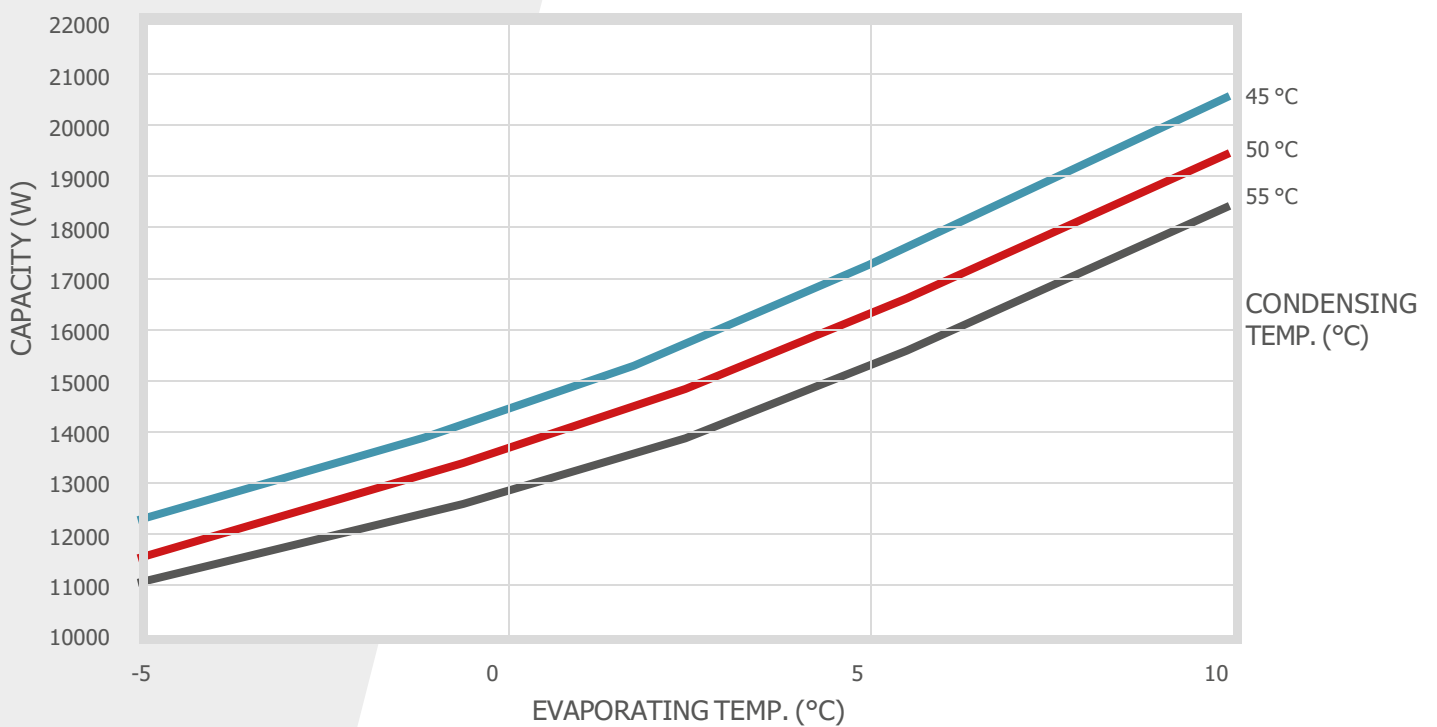
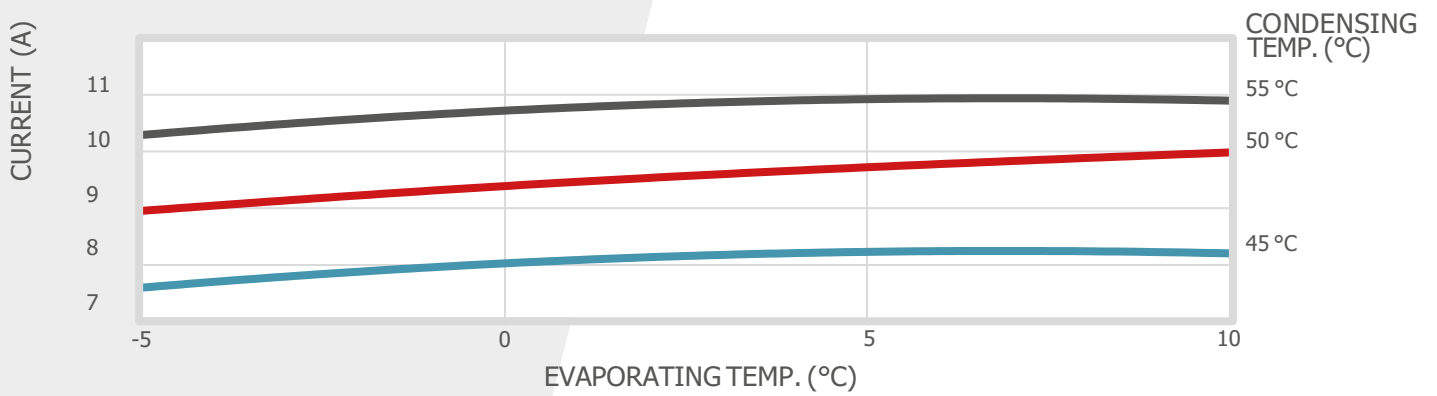
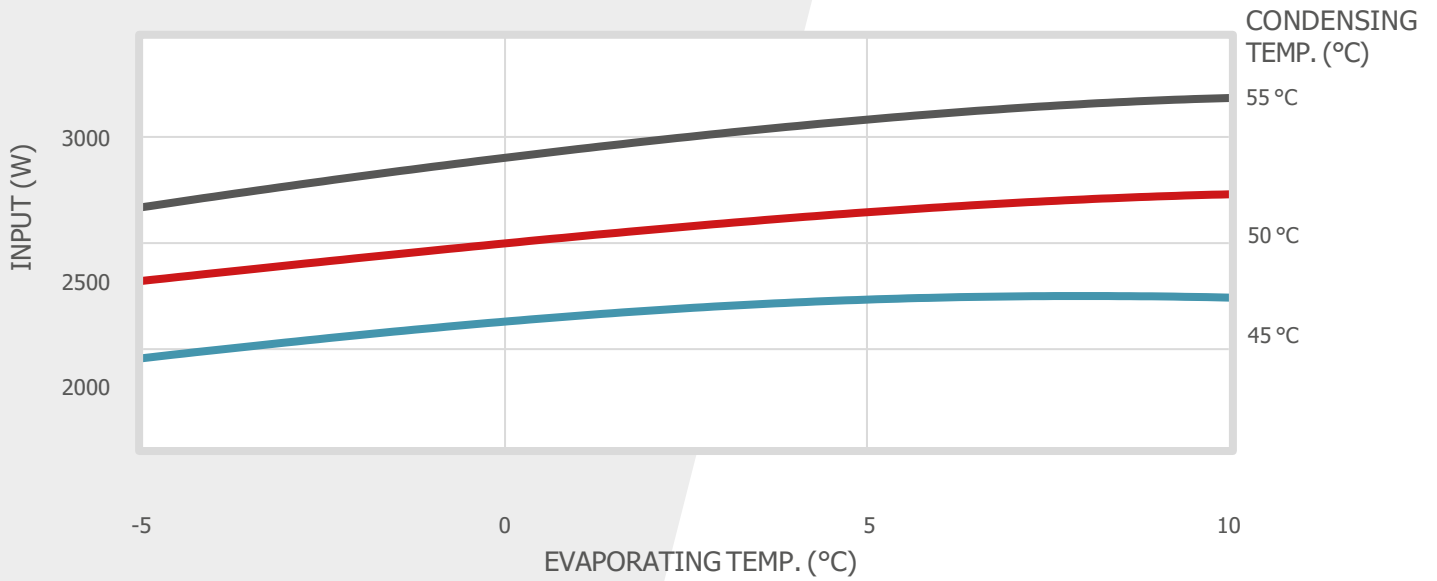

VRT18X1

ELECTRICAL CONNECTIONS

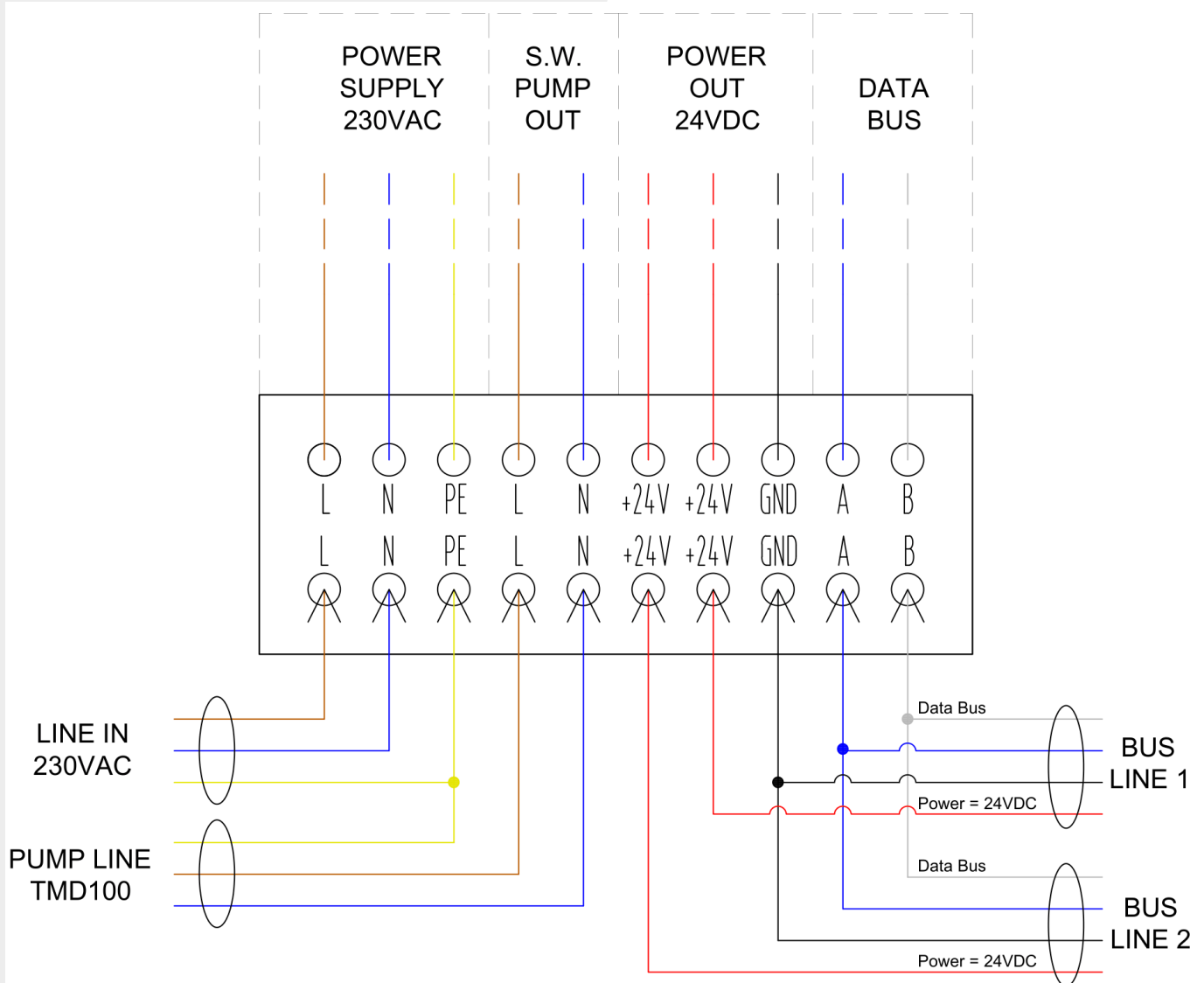

VRT18X1

OVERALL DIMENSIONS

