

CI100E2

DATASHEET

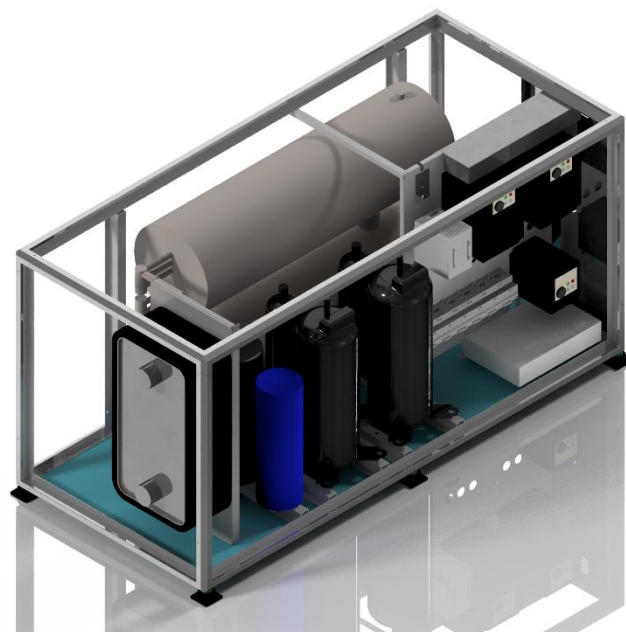

Cooling capacity KW	min 10	std 80	max 100
Cooling power source KW	min 3	std 16	max 25
Heating capacity KW	min 10	std 80	max 110
Heating power source KW	min 3	std 16	max 25

Power supply:

380 - 440 Vac / 50-60 Hz 3ph
700 Vdc on request

Sea water pump:

Magnetic type. Centrifugal. 500 lt/min 1,7kw included in compressor unit power

Water pipe size:

2"

Size W x D x H:

1579 x 720 x 780 mm

Weight:

191 Kg

Sea water working range:

+3°C to +40°C Option polar water: -5°C

Air working range:

-20°C to +50°C

Noise:

Compressor @ 70% – 52db @ 1 meter from box

Vibration:

No vibration

Compressor box use VRV inverter architecture with refrigerant circulation inside air handler

Databus rs485 modbus on board

System based on Toshiba VFD and twin rotary compressor



CONDENSER:

Titanium Grade 2. No fouling, no corrosion. 3 times lighter than copper nickel



COMPRESSOR:

Toshiba inverter twin rotary. COP > 4 Rotation speed: 600 to 6000 rpm



FRAME:

Aluminum silver anodized, Stainless Steel 316



SOFTWARE MANAGEMENT:

Compressor high temperature, low temperature, high pressure condenser, low pressure compressor, electronic pressure gas, electronic pressure liquid, Condensation control, Evaporation control



COMPRESSOR PROTECTION:

Over/undervoltage, overcurrent, torque, winding temperature, stepout (bad lubrication), power input, power output, efficiency, overload, oil level with infrared optical sensor



ELECTRONIC:

Microprocessor board with rs485 modbus rtu communication.
Interface to Termodinamica air handling unit or fresh air unit

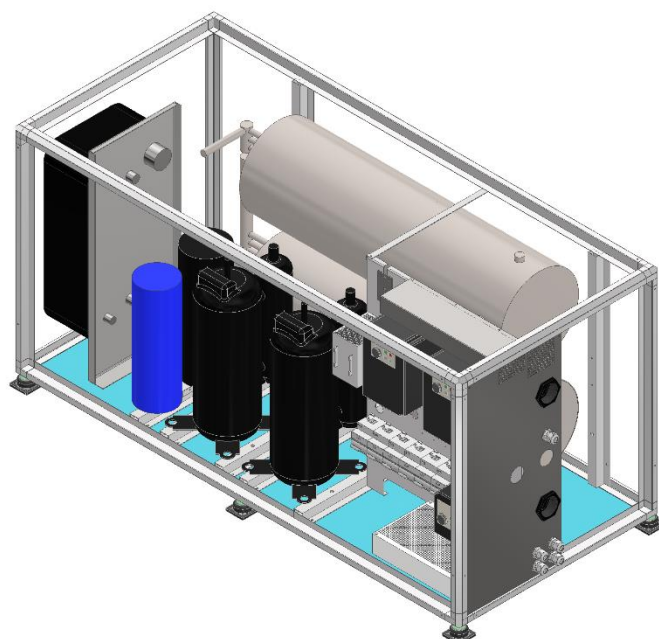
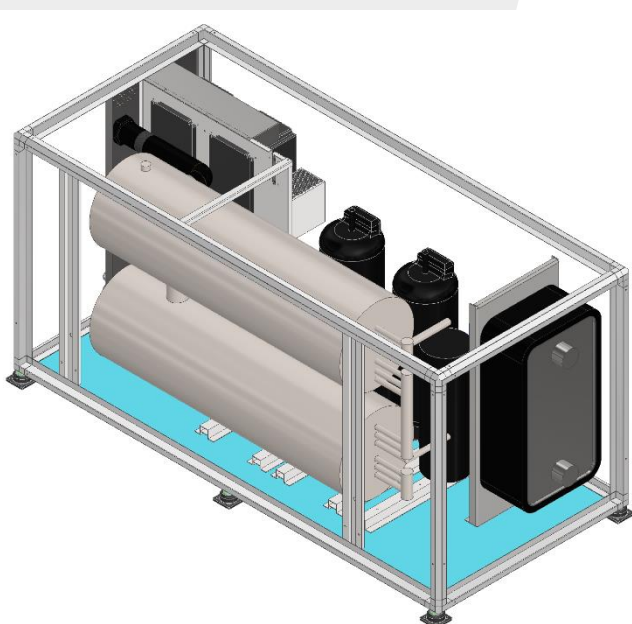

CI100E2

PERFORMANCE CURVE DC INVERTER 70 rps/100

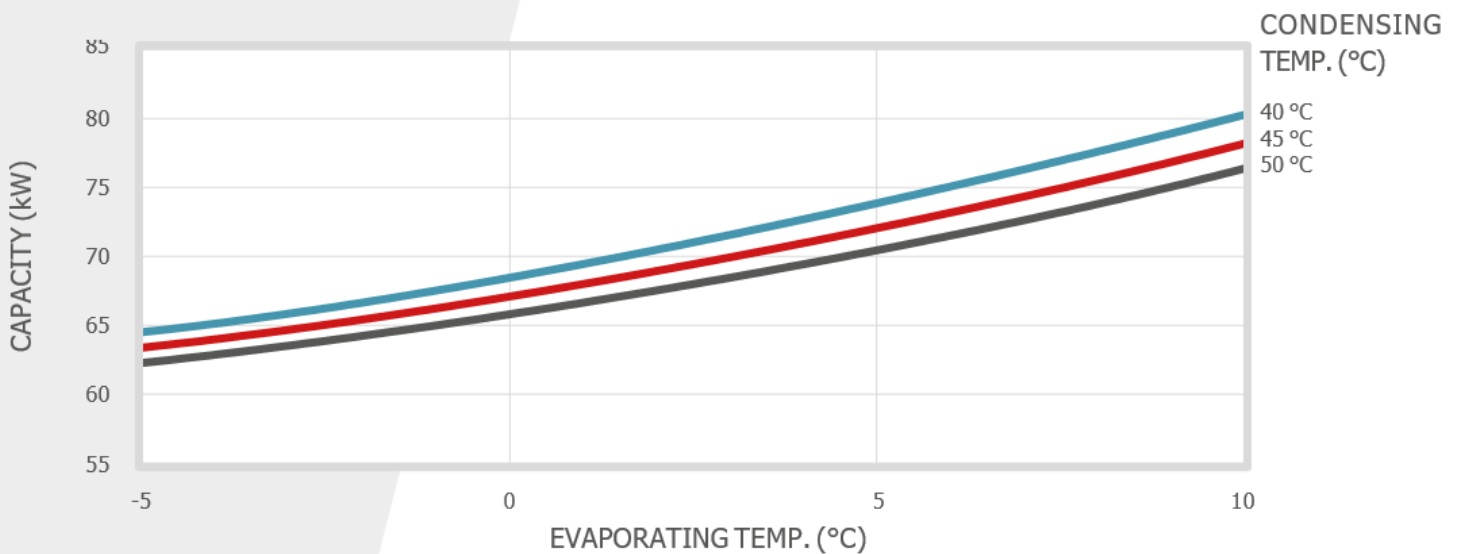
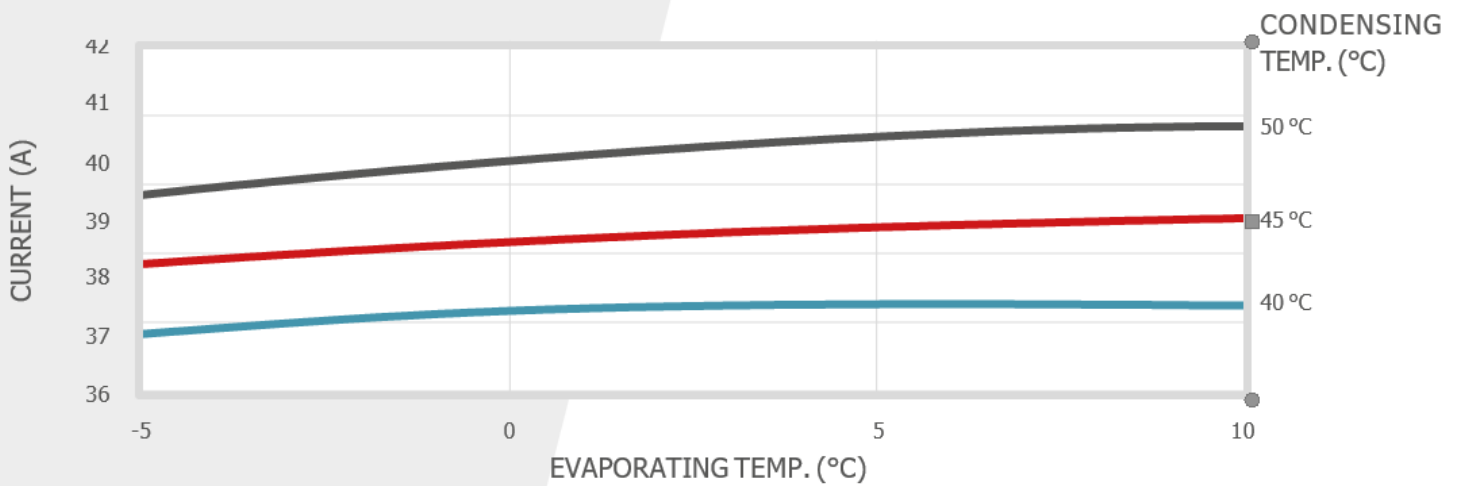
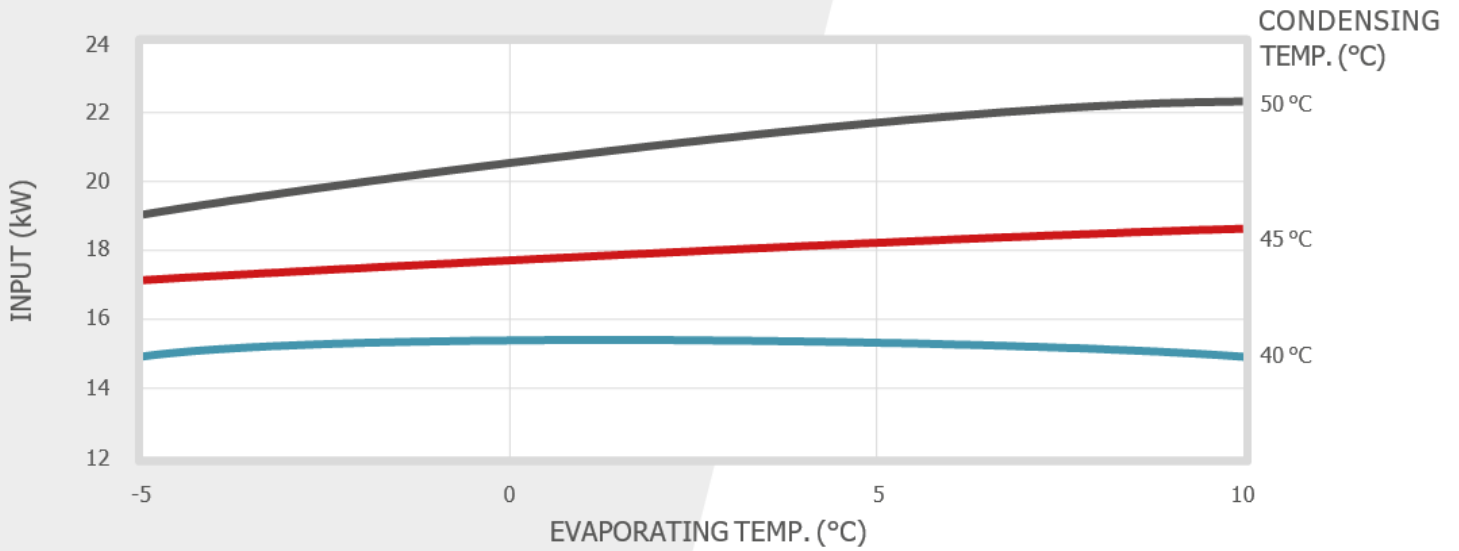

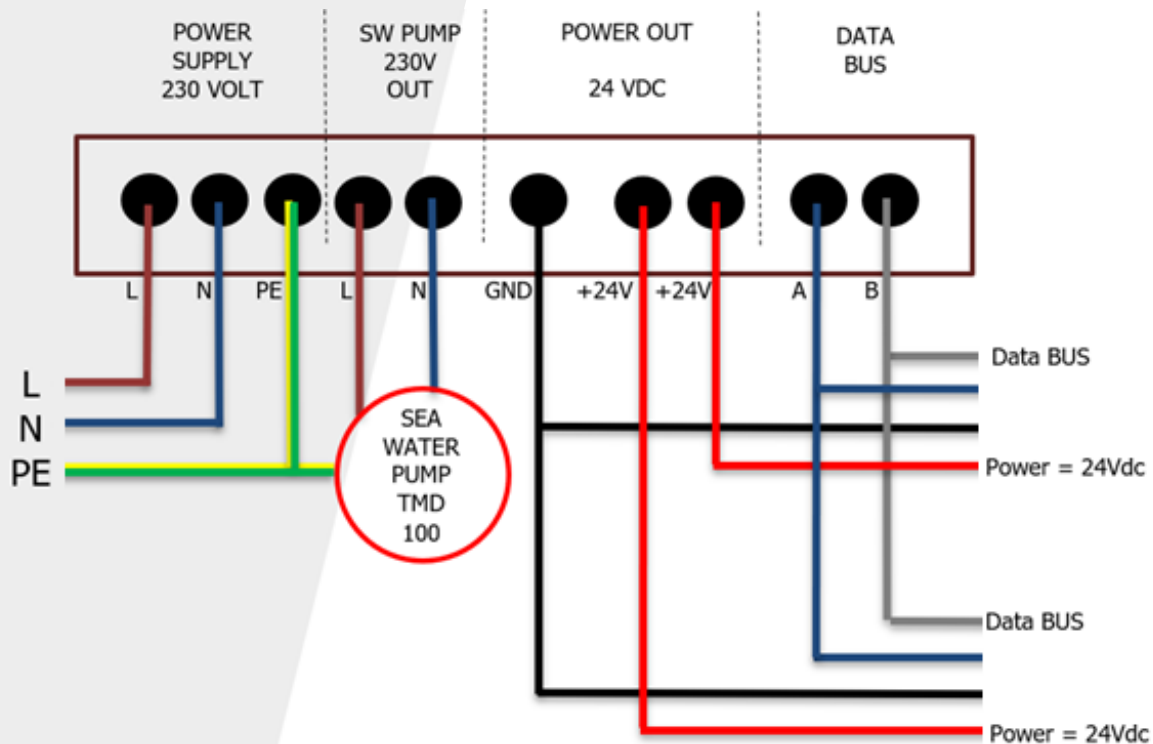

CI100E2

OVERALL DIMENSIONS

