

# VRV35E2

## DATASHEET

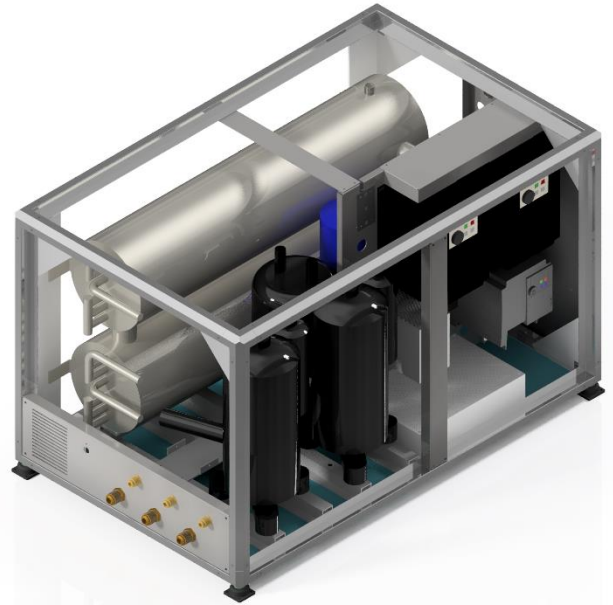

Cooling capacity KW	min 5	std 30	max 35
Cooling power source KW	min 1,5	std 5	max 9
Heating capacity KW	min 5	std 30	max 38
Heating power source KW	min 1,5	std 5	max 9

<b>Power supply:</b>	180 - 230Vac / 50-60Hz 1ph+N		
<b>Sea water pump:</b>	Magnetic type. Centrifugal 350lt/min 1kw included in compressor unit power consumption. Variable speed. 100 lt/min		
<b>Size W x D x H:</b>	1109 x 650 x 643 mm		
<b>Weight:</b>	138 Kg		
<b>Sea water working range:</b>	+3°C to +40°C		
<b>Air working range:</b>	-20°C to +50°C		
<b>Noise:</b>	Compressor @ 140 hz – 73db @ 1 meter from box		
<b>Vibration:</b>	No significant vibration transmitted to the feet		
<b>Sea water pipes connection:</b>	1" 1/2		
<b>Refrigerant pipe:</b>	3 x 3/4" Gas	3 x 1/2" Liquid	

Compressor box use VRV inverter architecture with refrigerant circulation inside air handler

Databus rs485 modbus on board

System based on Toshiba VFD and twin rotary compressor



### CONDENSER:

Titanium Grade 2. No fouling, no corrosion. 3 times lighter than copper nickel



### COMPRESSOR:

Toshiba inverter twin rotary. COP > 4

Rotation speed: 600 to 6000 rpm



### FRAME:

Aluminum silver anodized, Stainless Steel 316



### SOFTWARE MANAGEMENT:

Compressor high temperature, low temperature, high pressure condenser, low pressure compressor, electronic pressure gas, electronic pressure liquid, Condensation control, Evaporation control



### COMPRESSOR PROTECTION:

Over/undervoltage, overcurrent, torque, winding temperature, stepout (bad lubrication), power input, power output, efficiency, overload, oil level (with EEV)



### ELECTRONIC:

Microprocessor board with rs485 modbus rtu communication. Interface to Termodinamica air handling unit or fresh air unit

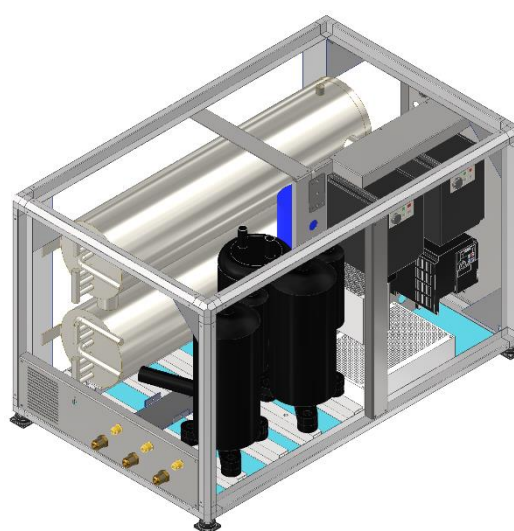
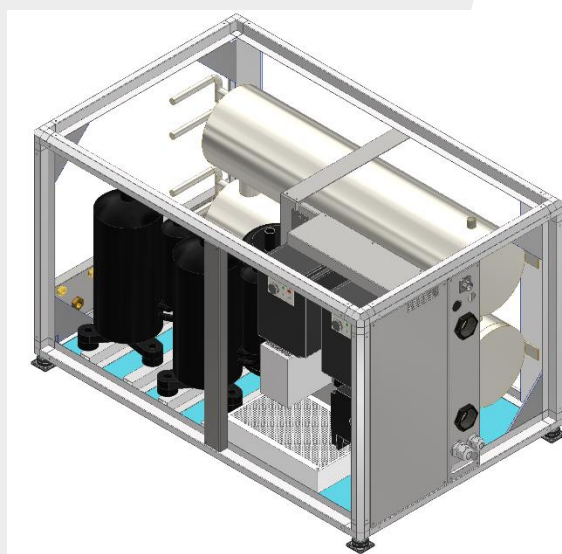

# VRV35E2 PERFORMANCE CURVE DC INVERTER 70 rps/ 100

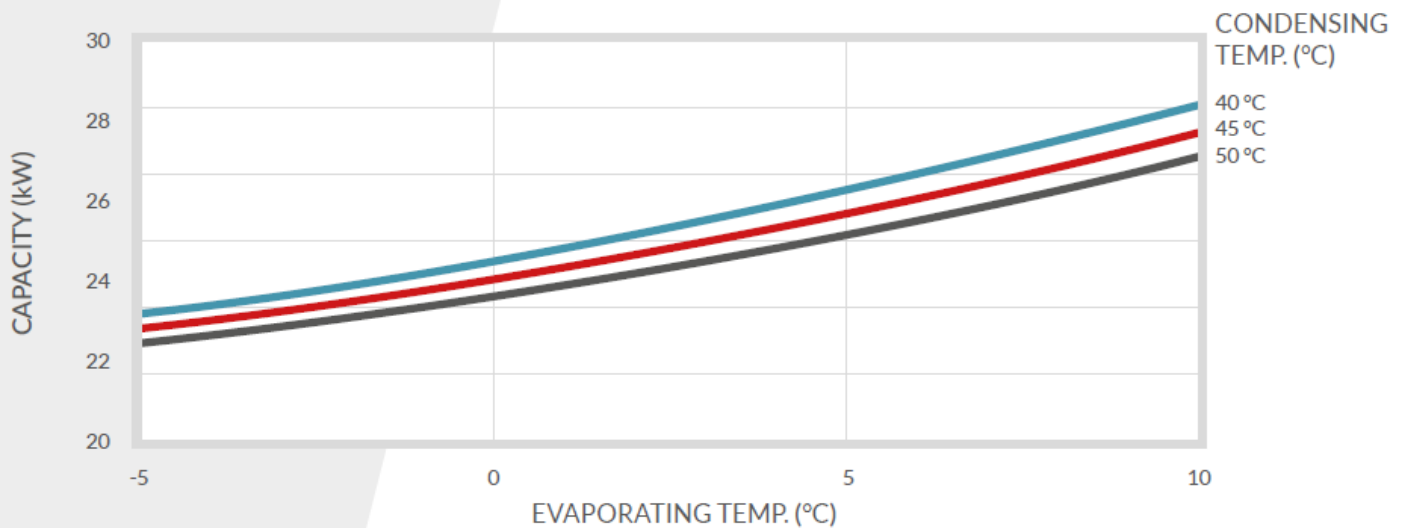
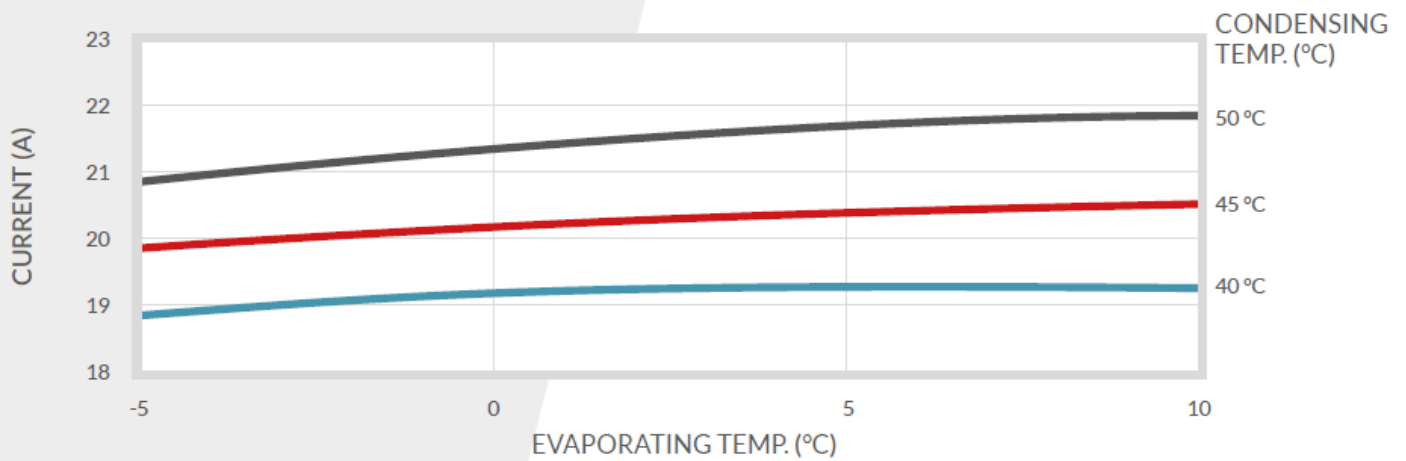
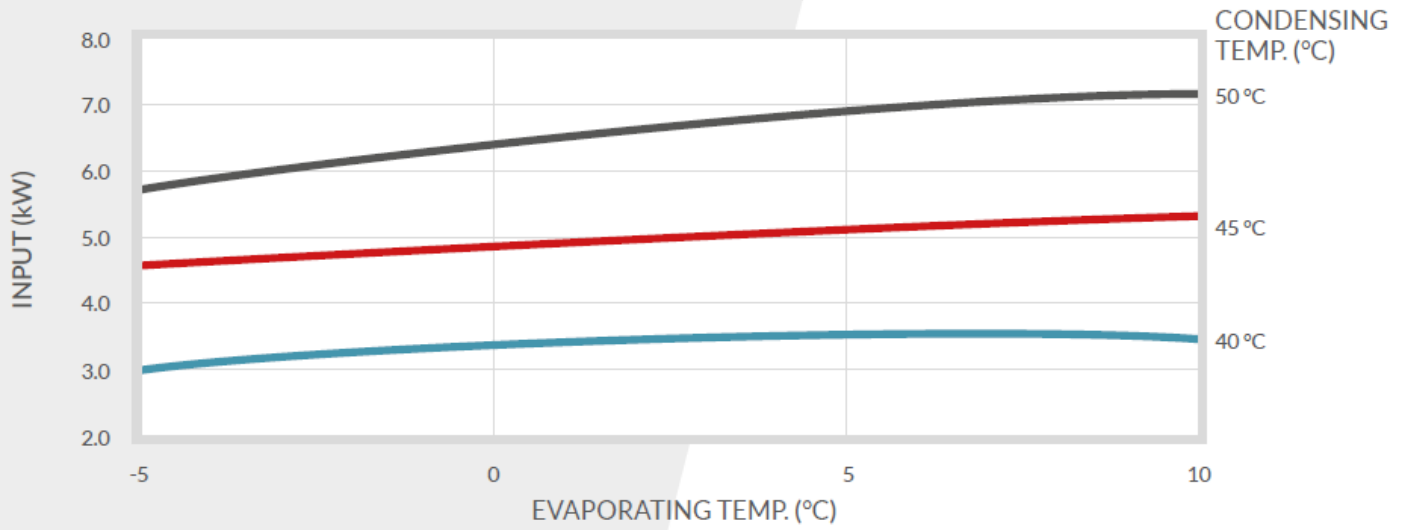

# VRV35E2

## ELECTRICAL CONNECTIONS

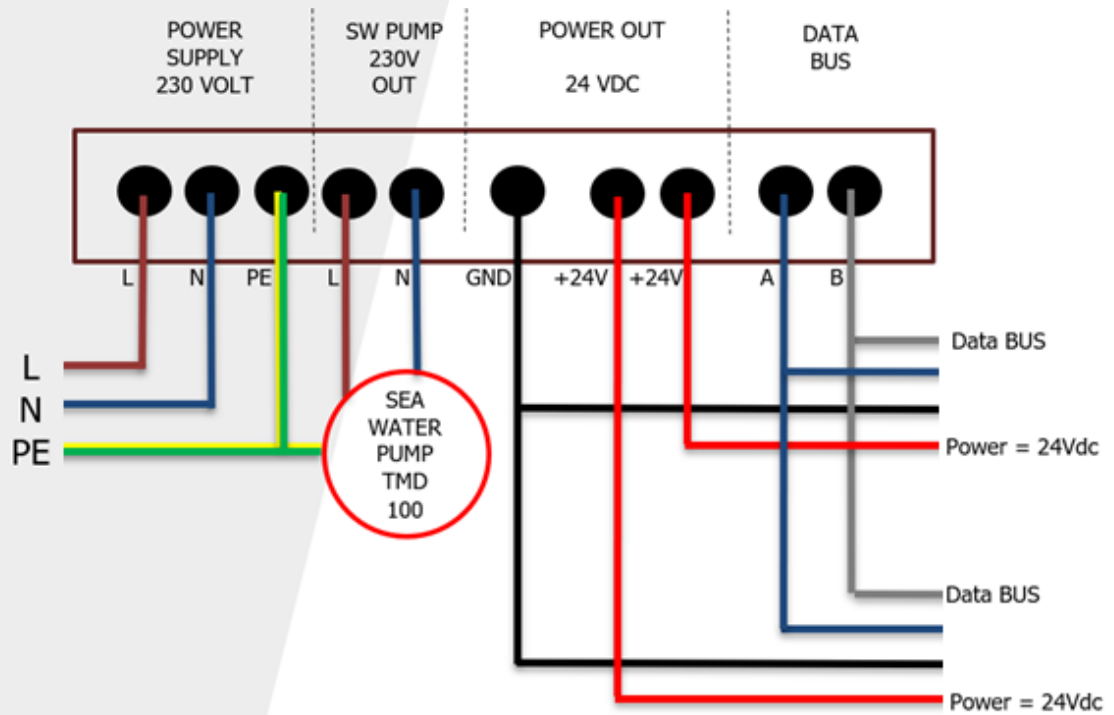

# VRV35E2

## OVERALL DIMENSIONS

