

EXH1000

DATASHEET

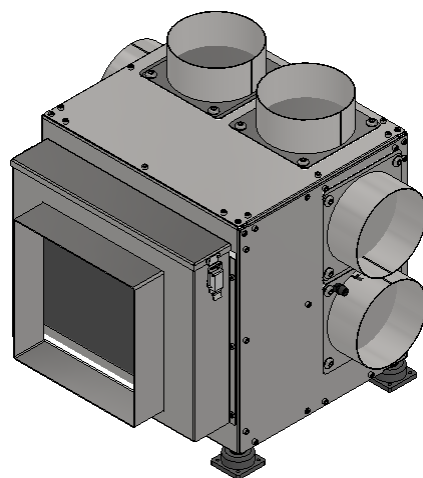

Capacity

Air flow 100-1000 m³/h

Static pressure:	600 Pa
Power supply:	230 Vac 50/60 Hz
Power consumption:	170 W (maximum)
Size W x D x H:	405 x 350 x 400 mm
Weight:	15 kg
Frame:	Stainless steel AISI316
Air duct size:	Custom made
Vibration	No significant vibration
Control	Data bus rs485 Modbus RTU

On request

Built-in Different Side extration	Top, Sx, Dx side extration
Built-in Different tipe of extration section	200x200 (square section), 200Ø (circular section)

EXH1000

Fan performance



Characteristics

Maximum power consumption: 170W

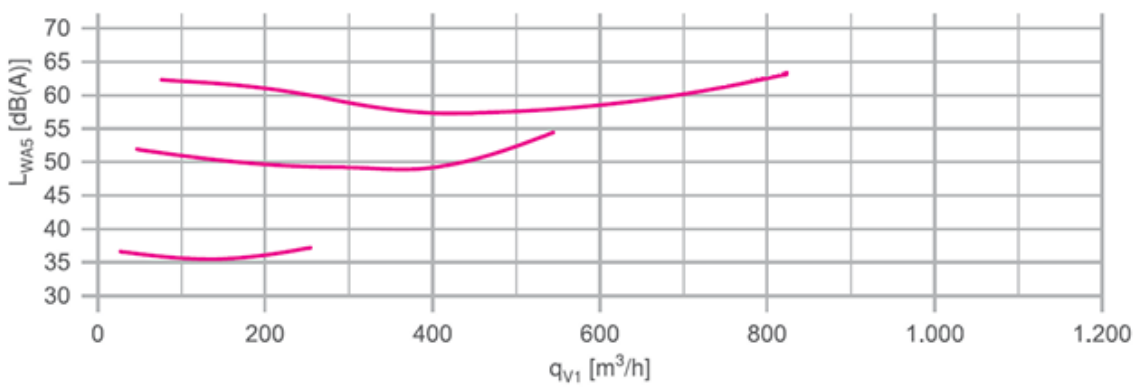
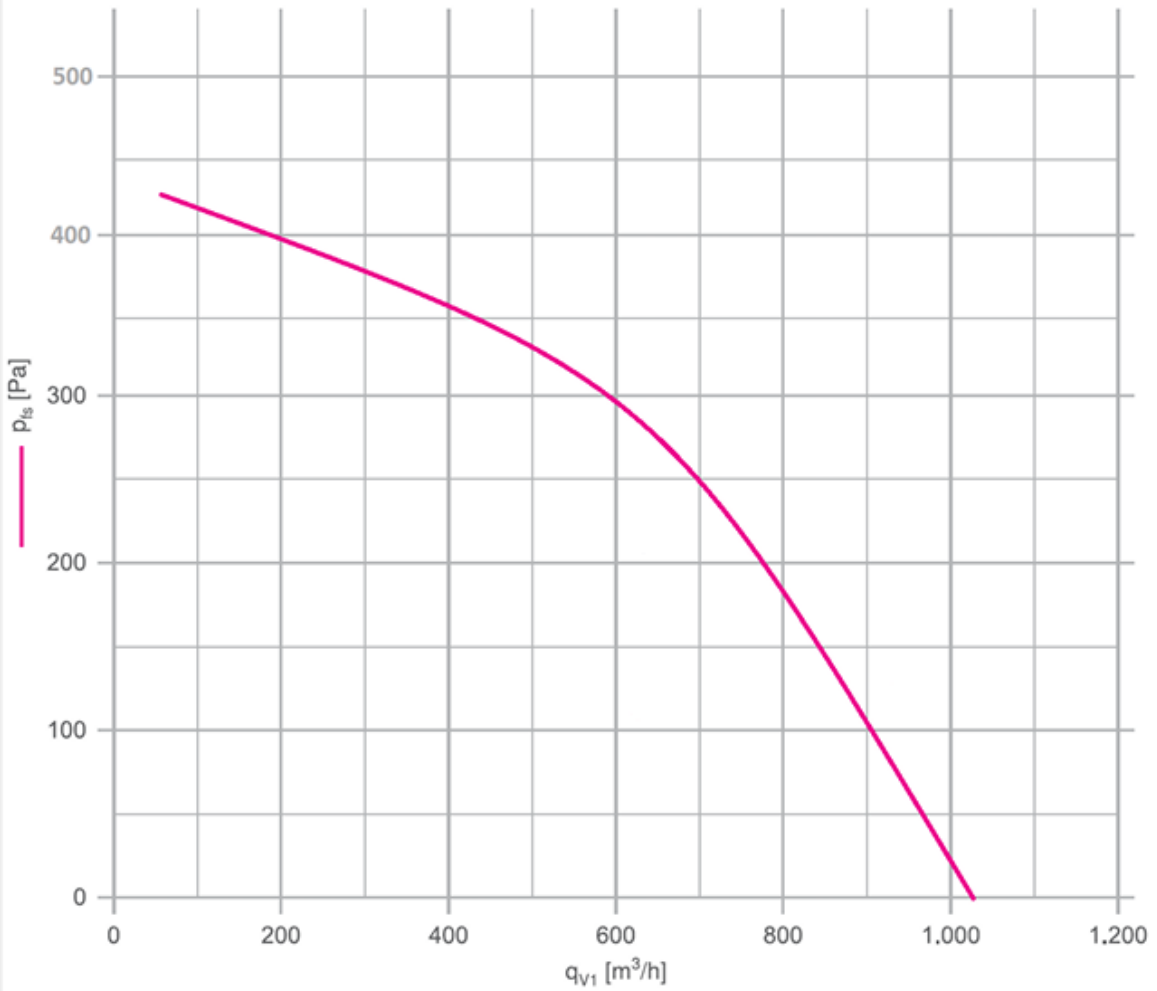

EXH1000

Overall dimension

